9 Forests in the Global Carbon Cycle: Implications of Climate Change

M.J. Apps, P. Bernier, and J.S. Bhatti

CONTENTS

9.1	Introduction	175
9.2	Climate Change and the Global Carbon Cycle.....	176
9.3	Human Perturbations to the Global Carbon Cycle	178
9.4	Forest Sources and Sinks at the Stand and Landscape Scale	178
9.5	Land-Based Carbon Sink and Its Future	184
9.6	Mitigation Opportunities.....	185
9.6.1	Forest Management to Increase or Maintain Terrestrial Ecosystem Carbon.....	186
9.6.2	Managing Products and Services Derived from Forests for C Benefits.....	187
9.6.3	Forest Products as a Manageable Carbon Pool.....	190
9.6.4	Use of Forest Biomass for Bioenergy	192
9.7	Conclusions: The Global Forest Sector and the Global Carbon Cycle.....	193
	Acknowledgments.....	195
	References.....	196

9.1 INTRODUCTION

As a consequence of human activity, Earth's climate has changed during the last 100 years and will change significantly for centuries to come.¹ The predicted changes for the next 50 to 100 years and beyond are both larger and faster than previously thought,^{2,3} and also more certain.⁴ Recent assessments indicate that, in the absence of purposeful mitigation interventions, it is likely that changes in the global mean temperature over the next 100 years will be at the high end of, or even exceed the IPCC 2001 predictions of +1.4 to 5.8°C above 1990 temperatures⁴ — itself a decade of record-breaking temperature.⁵

The change is not expected to be a simple linear increase in temperature or other climatic variable: abrupt and likely unpredictable changes similar to those seen in the geological record must be anticipated in the future. The impacts that have already been reported through the 20th century can be expected to intensify over the 21st, disrupting natural ecosystems and the services society has come to depend on, at all spatial scales from local to regional and global.

Moreover, the change has not been — and will not be in the future — distributed evenly over the Earth; climate change is greatest at mid- to high latitudes and over the continental landmasses found in North America, Europe, and Asia where large carbon pools are currently found in forest ecosystems. In these regions, local biogeochemical processes will likely experience profound changes in prolonged growing season, intensified incidence of drought and fire, systematic changes in annual snow accumulations, and an overall mobilization of large pools of ecosystem C, from forested uplands to forested wetlands.⁶

Climate change is arguably the most important environmental issue of the 21st century. It will have significant implications for resource management strategies. Are forests and forestry part of the problem or part of the solution?⁶ This chapter examines the contribution of northern forest ecosystems, especially the contribution of their management to the global carbon cycle.

9.2 CLIMATE CHANGE AND THE GLOBAL CARBON CYCLE

Throughout at least the last four glacial cycles, spanning nearly 1.5 million years prior to the 20th century, the atmospheric concentration of CO₂ only varied between ~180 ppmv during glaciations, when the global temperature was 8 to 9°C colder than today, and ~280 ppmv during the interglacial periods when the temperature was similar to present values (Figure 9.1A). This narrow range of variation in atmospheric CO₂ is remarkable given that its concentration is determined by a highly dynamic biogeochemical cycle. Every year, approximately 16% of the CO₂ in the atmosphere (approximately 760 Gt C) is taken up through photosynthesis by vegetation, and an almost identical amount is released by the respiration of vegetation and heterotrophs feeding on that vegetation. A similar exchange of ~90 Gt C yr⁻¹ takes place at the ocean surface where phytoplankton provide the photosynthetic engine driving the exchange.⁷

This generally tight domain of stability between variations in CO₂ and global temperature (Figure 9.1B) suggests that the global carbon cycle has been controlled by powerful biological feedback processes that have maintained the climate in a habitable range. The biosphere appears to play a central role in regulating Earth's climate, a suggestion strongly reinforced by the physics of the greenhouse gas feedbacks. The biosphere–climate system coupling includes other factors, such as surface reflectance properties (albedo), that have effects both regional and global in extent (see, e.g., Reference 8), but here our focus is restricted to the global carbon cycle.

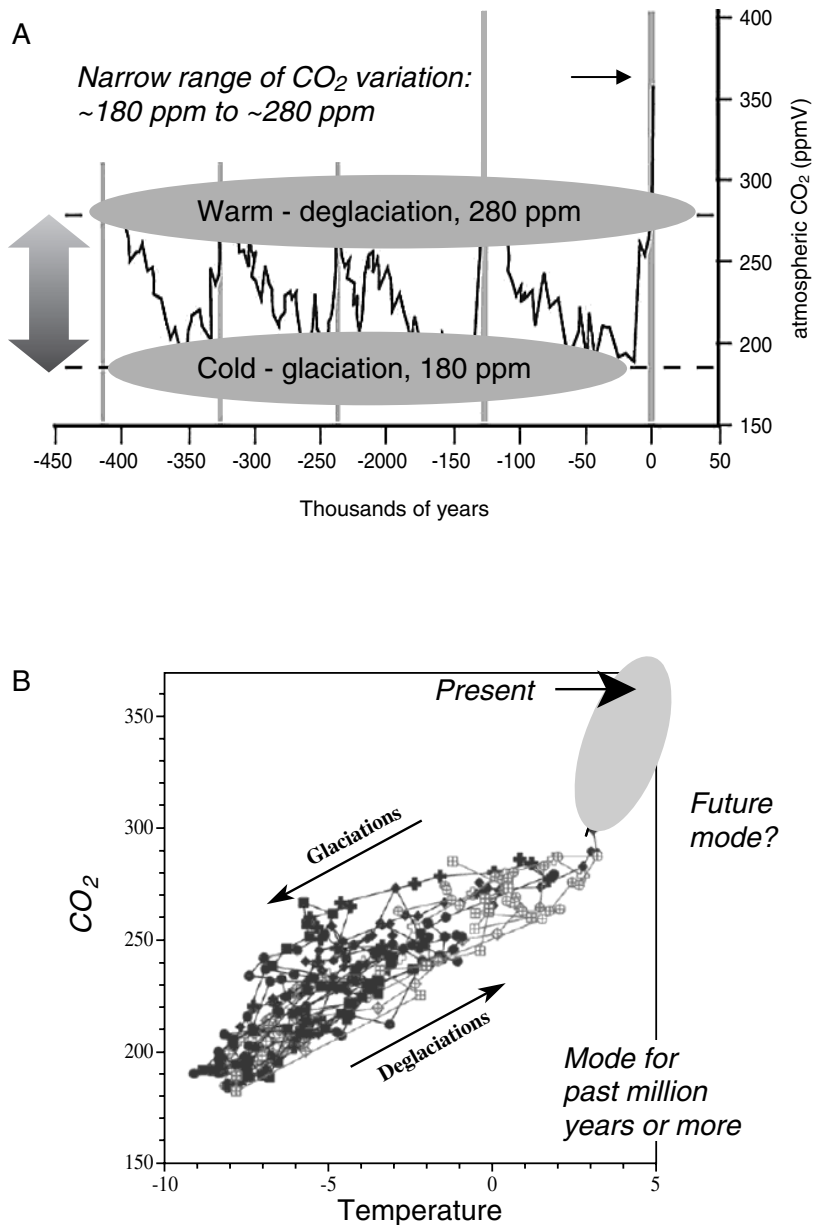

FIGURE 9.1 (A) Variation in atmospheric CO₂ from analysis of ice cores over four glacial cycles during the last 420,000 years. Present levels (>360 ppmv) are indicated by the arrow. (B) The stability domain of atmospheric CO₂ and global temperature over the last four glacial cycles, showing recent departures and possible shift to a new domain of unknown stability. (Adapted from Falkowski et al.⁷)

In contrast to the long-term record, the atmospheric CO₂ concentration today is ~370 ppmv — nearly 100 ppmv higher than at any time in at least the past 1.5 million years — as a result of human perturbations to the global carbon cycle. The concentration is also rising at a rate that is at least 10, and perhaps as much as 100, times faster than ever before observed.⁷ Clearly, the biosphere's ability to regulate the global carbon cycle — and hence the climate system — has been exceeded by human-induced carbon emissions.

9.3 HUMAN PERTURBATIONS TO THE GLOBAL CARBON CYCLE

Human perturbations to the carbon cycle have been both direct and indirect (Figure 9.2). On land, human activities have modified vegetation patterns and functioning in global proportions, while changes to freshwater inputs and pollutant eutrophication of the oceans have altered their ecology as well. In other words, humans have changed the very nature of the biospheric systems that are responsible for biospheric exchange of CO₂. In addition, and more significantly, human use of fossil fuels has introduced additional, new carbon into the active* global carbon cycle through the combustion of fossil fuels. Deforestation — removal of forest vegetation and replacement by other surface cover — has had a twofold impact on the carbon cycle: the loss of photosynthetic capacity in forest vegetation, and the release of the large carbon stocks that had accumulated in these forest ecosystems over long periods. Indirect human impacts on the carbon cycle include changes in other major global biogeochemical cycles (especially nitrogen),⁹ alteration of the atmospheric composition through the additions of pollutants as well as CO₂, and changes in the biodiversity of landscapes and species — all of which are believed to significantly influence the functioning of the biosphere.

9.4 FOREST SOURCES AND SINKS AT THE STAND AND LANDSCAPE SCALE

A forest ecosystem is a sink (source) when it effects a net removal (release) of atmospheric CO₂. The sink results when the uptake through photosynthesis results in an increase in the sum of the carbon stocks retained in the forest vegetation itself and in the stocks of organic carbon in other material derived from the forest. The most important of these derived reservoirs are the detritus and soil organic matter pools. The net carbon balance of the ecosystem may be calculated as the net change over time in total ecosystem carbon stocks (dC_{ecosys}/dt , where C_{ecosys} is the sum of carbon stocks in vegetation, forest floor and soil). Ignoring for the moment any export of organic carbon from the ecosystem, the net carbon balance is identical to the net ecosystem productivity (NEP):

* "Active" is used here to distinguish the carbon pools and processes that dominate the exchange that occurs on time scales of order of years to decades from those that are important on geological time scales, such as the accumulation of organic carbon in fossil fuel deposits.

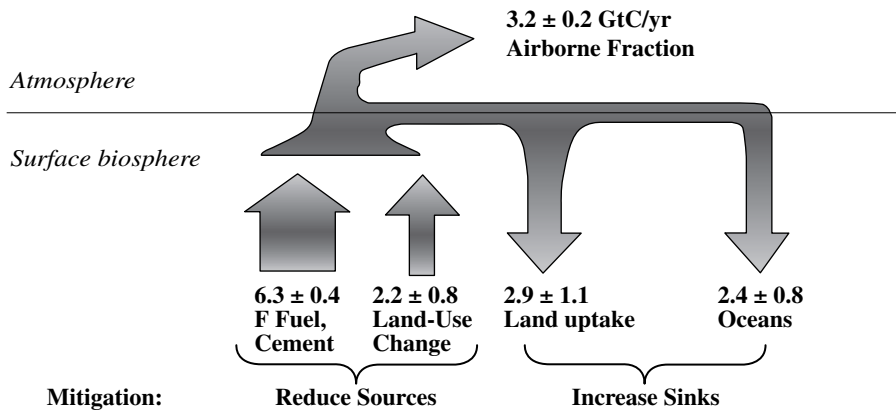

FIGURE 9.2 Human-induced perturbations (Gt C yr^{-1}) to the global carbon cycle during the 1990s. The arrow widths are proportional to the fluxes. Land uptake is inferred as the residual required to balance the other fluxes with the observed accumulation (airborne fraction) in the atmosphere. (Data from Houghton.¹⁰)

$$\text{Net Carbon Balance} = dC_{\text{ecosys}} / dt \quad (9.1)$$

$$dC_{\text{ecosys}} / dt = \text{NEP} = \text{GPP} - R \quad (9.2)$$

where GPP (gross primary production) is the rate of CO_2 uptake by foliage through photosynthesis and $R = R_a + R_h$ is the total ecosystem respiration flux comprising autotrophic (plant) respiration R_a and heterotrophic respiration R_h (decomposition) of the accumulated detritus and soil pools.

The term net biome production (NBP) is sometimes used to account for exported carbon and its subsequent decomposition outside the ecosystem:¹¹

$$\text{NBP} = \text{NEP} - R_{\text{exp}} \quad (9.3)$$

where R_{exp} is the flux of carbon transferred out of the ecosystem. Forest products form an important part of the offsite carbon pools in that the timing and manner of their decomposition is (in principle at least) under human control.

Figure 9.3 shows the conceptual pools and transfers of carbon involved in forest ecosystems and the forest sector. To provide a comprehensive system, the ecosystem compartments (vegetation and detritus and soil pools), the exported pools that are located offsite (including forest products and the waste created during their manufacture and abandonment in landfills), and the influence of the forest sector on fossil fuel use are all included.

The net accumulation of carbon in the ecosystem (or the larger system shown in the figure) is thus a summation over time of the difference between a large ingoing CO_2 flux (GPP) and a nearly equal outgoing flux (R). Different processes, whose rates differ over time and space and vary both with environmental conditions and the state of the ecosystem, control the two fluxes. The processes involved include

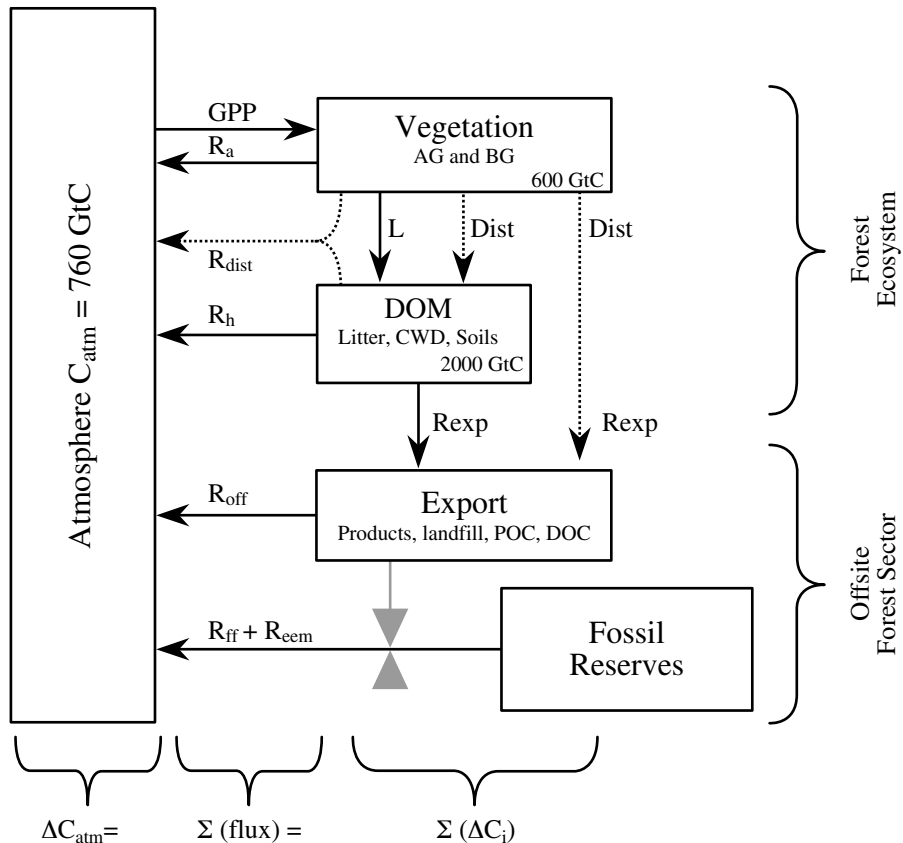

FIGURE 9.3 Carbon fluxes (arrows) and pools (boxes) involved in the forest sector budget. Smoothly varying fluxes include GPP = gross primary production, R_a = autotrophic respiration, R_h = heterotrophic respiration, R_{off} = offsite respiration, L = litter fall (above- and belowground AG and BG) and leaching from DOM (dead organic matter) on the forest floor and in soils. Pulsed fluxes (dotted lines) are associated with disturbances. R_{exp} , the carbon flux that is exported to offsite carbon pools, has both a smooth component (leaching) and a pulsed component (from disturbances). Fluxes from offsite carbon pools (products, landfills, POC = particulate organic carbon, DOC = dissolved organic carbon in water or air) are lumped into one flux R_{off} . The influence of bioenergy and use of forest products on fossil fuel use is shown as a control valve on fluxes from fossil fuel use (R_{ff}) and cement production (R_{cem}) production.

both those regulating the internal redistribution of organic carbon within the ecosystem, such as allocation of photosynthate within the plants and breakdown of fresh litter into less decomposable forms of soil organic matter, and disturbances (such as windthrow, insect predation, harvest, or fire).

Disturbances are discrete events that are particularly interesting because they generate large pulses of internal transfers of carbon between pools within the ecosystem or out of it (e.g., harvest). They therefore bequeath a legacy of increased decomposition emissions in the future. In addition, disturbances such as fire may

also generate large, immediate CO₂ releases to the atmosphere. The complex set of processes — operating independently over a range of timescales — gives rise to rich variation in NEP (and NBP) in both time and space.

The net carbon balance in a forest ecosystem (NEP) can be estimated by summing all the changes in ecosystem carbon stocks (the “stock inventory” method), direct measurement of the net exchange of CO₂ with the atmosphere (using, for example, eddy covariance techniques), or a combination of these methods. Provided all stocks and fluxes are accounted for, the approaches must give identical answers (a result of the principle of conservation of mass), as has been shown by careful experiments at the Harvard forest and several other locations.¹²

The net carbon balance of a stand of trees or patch of forest varies with the prevailing conditions that affect both the rates of CO₂ uptake and release (Figure 9.4A). It also depends very strongly on the past history of the stand or site. For example, the net carbon balance (NBP) of a clear-cut stand is initially highly negative (when the harvest carbon is removed from the site — an export flux not directly captured by net ecosystem exchange flux measurements) and remains so for several years while the releases of CO₂ from decomposition of slash and soil carbon exceeds the CO₂ uptake of regrowing vegetation. Eventually the uptake through regrowth exceeds decomposition efflux, at which time above- and belowground detrital production starts to rebuild the depleted stocks on the forest floor and in the soil. NEP then rises steeply to a maximum rate that typically occurs around or shortly after canopy closure. As the ecosystem continues to age and more organic carbon accumulates in the vegetation, forest floor, and soils, the respiration efflux from these reservoirs also increases. Rates of photosynthetic input tend to level off as the stand approaches maturity, and net primary productivity may even decline when stand-breakup occurs in overmature stands.^{13,14} Thus in older stands, the net carbon balance (NEP) tends toward zero (or even becomes negative) as decomposition of the soil and detritus layer approaches that of the photosynthetic inputs. In some ecosystems, such a decrease in NEP may take a very long time after the last carbon-removing disturbance.¹¹

At the landscape (or biome) scale, a forest comprises many stands of trees (individual ecosystems) in various stages of development (Figure 9.4A), and the net carbon balance at this scale is the integration across all such ecosystems in the landscape. Here, for illustrative purposes, only even-aged forests such as are found in disturbance-dominated natural forests or in clear-cut plantations are considered: the principles apply, however, to all forests. For forests dominated by even-aged stands, the stand age-class distribution can be used to facilitate the summing across ecosystems in different stages of development. For a forest comprising only one ecosystem type, the total ecosystem carbon in the landscape is

$$C_{\text{landscape}} = \sum_{i=1}^N C_i A_i \quad (9.4)$$

and its change over time is

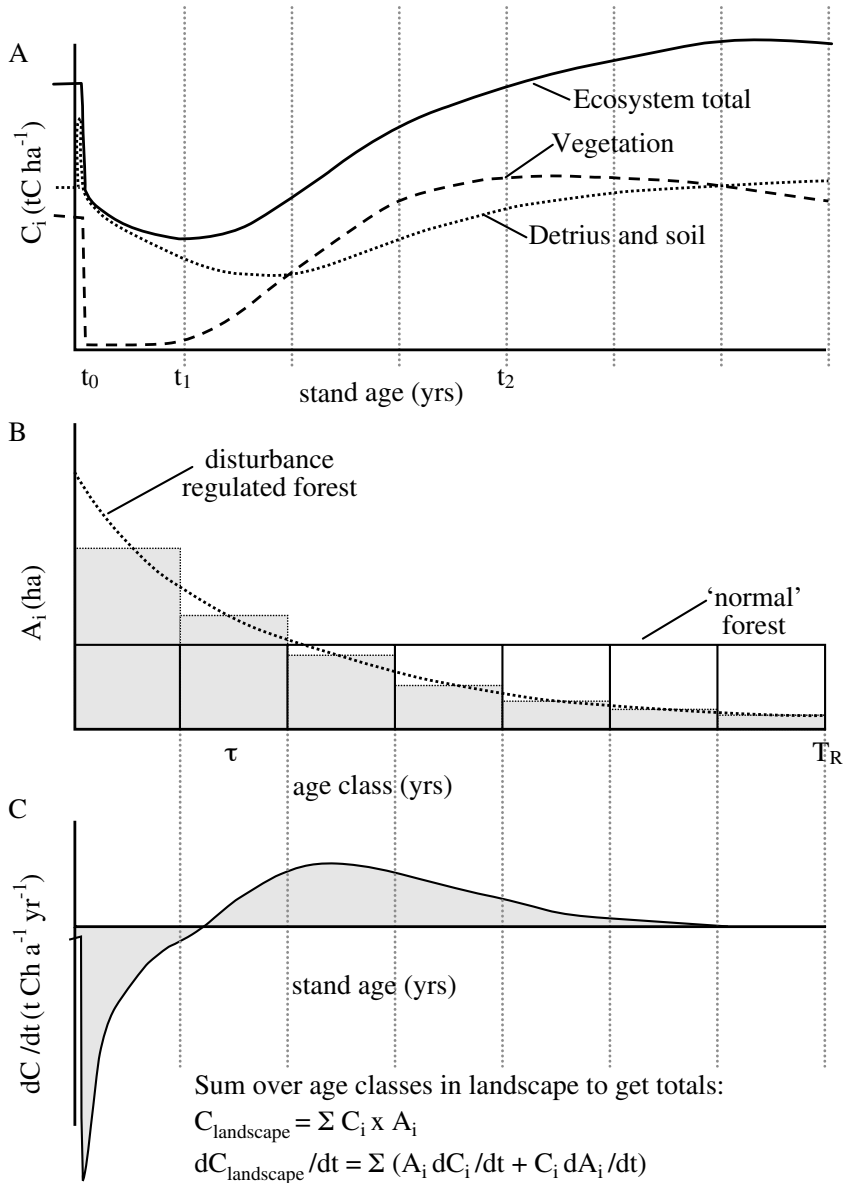

FIGURE 9.4 Carbon dynamics at the stand and landscape scale: (A) stand-level C dynamics after disturbance at t_0 . The stand is a source until t_1 , but does not recover C lost at an immediately after the disturbance until t_2 ; (B) stable age-class distributions for “normal forest” (rotation T_R) and random disturbance-regulated forest (return interval t); (C) stand-level accumulation rate. For landscape pools, sum product of $a * b$ over all age classes; similarly sum product of $c * b$ for changes in pools in unchanging conditions.

$$dC_{\text{landscape}}/dt = \sum_{i=1}^N (A_i dC_i/dt + C_i dA_i/dt) \quad (9.5)$$

where A_i is the area (ha) of forest in age class i , and C_i is the carbon concentration (Kg C ha^{-1}) of this age class. For a more general heterogeneous forest, the total landscape carbon involves additional summations over all the distinguishable ecosystem types (each characterized by a different carbon accumulation curve). Moreover, the actual carbon accumulation curve (Figure 9.4A and C) changes with disturbance type and intensity as each may leave different amounts of litter and hence different legacies of decomposition pulses; the actual site history has a direct effect. This generally involves additional summations over disturbance types and inevitably requires historical information about past disturbance regimes.¹⁵

Changes in the net carbon accumulation at the landscape scale (Equation 9.5) thus has two components:

1. Changes in productivity of the individual ecosystem growth and respiration responses to environmental variations (functional response, alterations to curves in Figure 9.4A and C)
2. Changes in the age-class distribution associated with landscape variation in mortality and recruitment (structural response, alterations to curve in Figure 9.4B)

Over long enough times, succession alteration to the distribution of vegetation types will also take place, providing further structural and functional responses and changes in NEP.

At any given time, the age-class distribution is a direct result of the cumulative effects of mortality and recruitment to that point in time, and for the even-aged forests discussed here, is a direct reflection of the history of past disturbances. Under a steady disturbance rate (such as a constant fire return interval, or a fixed harvest rotation), the balance between mortality and recruitment leads to a stable age-class distribution that can maintain its shape over time. An example of such distributions is the managed “normal forest”¹⁶ associated with sustainable harvesting and regeneration of stands in a plantation, in which each age-class occupies an equal area up to the rotation age T_R (Figure 9.4B). Another example is the (approximately) exponential age-class distribution (also shown in Figure 9.4B) that is associated with randomly occurring disturbances, applied with equal probability to all ages, and having a constant mean return rate and variance. Such distributions are often found (but not always) with naturally occurring disturbances such as wild fire, windstorms, and some insect outbreaks.^{17,18}

Sources and sinks at the landscape scale are created when the disturbance rate changes. If the disturbance rate increases, the age-class distribution shifts to the

^{*} The term “normal” is used here in a technical sense (see MacLaren¹⁶) and not as the common adjective to imply “usual” or “average.”

left (younger), and the total carbon retained in the ecosystems in the landscape decreases. The landscape becomes a net source of CO₂ to the atmosphere while its age-class distribution adapts to the new disturbance regime. (If some of the lost carbon is transported out of the ecosystem landscape to decompose in offsite reservoirs, such as the case of forest products, the landscape source is reduced by that amount — in essence this component of the source is exported.) Similarly, if disturbances are suppressed, the ages shift to the right, the forest ages and carbon stocks increase with a net removal of CO₂ from the atmosphere. Taking changes in disturbance regimes into account is clearly important in predicting the future carbon budgets of forested regions.

9.5 LAND-BASED CARBON SINK AND ITS FUTURE

Until recently, the net land-based carbon sink required to balance the perturbed global carbon budget (Figure 9.2) was thought to be fully explained by changes in ecosystem functioning. Enhanced forest uptake rates (increased GPP) associated with elevated atmospheric CO₂, increased nutrient inputs from pollution, and a positive response to global temperature increases were used to close the global budget. However, although physiological mechanisms and normal climate variations may explain some of the short-term changes (seasonal to inter-annual) in forest ecosystem uptake (GPP), their ability to cause longer-term net uptake and retention (GPP-R) has been questioned by a number of authors (e.g., References 19 and 20).

It is now recognized that changes in the structure of ecosystems, especially the age-class structure of forests, are at least as important as the functional changes. For example, changes in land-use practices, such as abandonment of marginal agricultural lands to forest and the rehabilitation of previously degraded or deforested lands has been shown to be largely responsible for the putative North American sink,²¹ and a much larger contributor than any of the proposed physiological mechanisms such as CO₂ fertilization.²²

Change in the climate regime may also affect current carbon pools of forests, although the direction and magnitude of these changes is still uncertain and difficult to predict. Over periods of years to decades, the stimulation of GPP through longer growing seasons should result in increased vegetation biomass, an effect that may already be apparent in the global atmospheric CO₂ record.²³ However, although GPP may increase with increased temperature, so may the heterotrophic decomposition rate — approximately doubling for each 10°C increase in soil temperature. Given the very large size of the C stocks in forest litter and soil pools, this gives rise to concern that increased heterotrophic respiration may generate a positive feedback mechanism to climate change by releasing additional quantities of CO₂ in the atmosphere. Recent work, however, suggests that in some ecosystems, increased heterotrophic respiration may be largely offset by increased detrital production by trees, leaving detrital and soil carbon content relatively unchanged as long as the forest composition remains unaltered.²⁴

At longer timescales (decades to centuries and longer), changes in the vegetation itself take place through successional processes as the ecosystems adapt to changing conditions. These longer-term changes may lead to either greater carbon stocks, as

in more productive forest ecosystems, or smaller stocks, as in a transition to a grassland ecosystem. Comparison of relative pool sizes for boreal, temperate, and tropical forests suggests a general shift of dominance from belowground to aboveground stocks as temperatures warm. Over the intermediate term, the expansion of forests into existing nonforest regions, such as the northward expansion of the boreal forest, may provide some additional uptake. This expansion, however, is a slow and uncertain process (e.g., Reference 25) and over the short term will likely be more than offset by possible dieback of forests at the other end of their range. Such dieback and transition to grasslands in southern boreal forests in south central Canada have been suggested by several authors,^{26–28} and can happen extremely quickly if driven by more frequent or more intense large-scale disturbances such as fire.²⁹ One of the major causes of uncertainty is the unprecedented rate of current climatic changes that are taking place over timescales that are out of synchrony with the dominant processes of some ecosystems and beyond their adaptive capacity.³⁰

In addition, for each of the stimulation mechanisms there typically exists limiting factors that eventually counteract it over time.¹⁹ Elevated levels of ambient CO₂ increase the photosynthetic efficiency of foliage, but as the concentration increases, this stimulation decreases and saturates at atmospheric concentrations that may be reached in the next 50 to 100 years.³¹ To date, *in situ* fumigation of stands with elevated CO₂ for periods for 3 years has yielded consistently high GPP values, but the future of this effect remains uncertain.³² Although initial response to increased N inputs associated with atmospheric pollution is growth enhancement, at higher loadings (already reached in some areas), the effects of acidification may lead to net decreases.^{33,34} Moreover, there is good evidence that the response of forest ecosystems to either CO₂ or N fertilization will be short-lived when other required resources, such as water or other nutrients, become limited. Results from stand-level fumigation studies also show that tropospheric ozone may counteract the growth enhancement offered by increases in CO₂.³⁵ Thus, while many ecosystems studied to date indicate an initial positive response in NEP to these manipulations, they also show an acclimation over time to these stimuli — usually interpreted as a combination of subtle changes in the ecosystem structure and the onset of another limiting factor.³

Finally, there are concerns that climate change will bring about changes in the disturbance regimes (rate, intensity, and form). Although fire³⁶ is the best known of these disturbances, changes in insect dynamics, drought stress, ozone and ultraviolet damage, and damage from hurricane or severe storms may be more important in some regions.^{37–40} The impact of changes in disturbance regime over the last few decades in Canada's forests — suggestive of, but not definitively shown to be due to climate change — appears responsible for a shift of these forests from a significant sink to a small source of atmospheric CO₂.¹⁵

9.6 MITIGATION OPPORTUNITIES

There are two fundamental mitigation interventions:

1. Reduce emission sources, or
2. Increase sinks

Land management, and especially forestry and forest management, can contribute to both of these opportunities. Interventions that maintain healthy ecosystems can also maintain, or even increase, land-based carbon stocks. Using forest goods and services can simultaneously help to reduce anthropogenic emissions of CO₂ typically generated by alternative supplies of these goods and services. These two opportunities are not mutually exclusive, and will be briefly described in very broad terms.

9.6.1 FOREST MANAGEMENT TO INCREASE OR MAINTAIN TERRESTRIAL ECOSYSTEM CARBON

The ultimate aim of mitigation strategies, such as put in place by the Kyoto Protocol, is “the stabilization of greenhouse gas concentrations in the atmosphere at a level that would prevent dangerous anthropogenic interference with the climate system.”⁴¹ Mitigation strategies that promote the preservation and maintenance of healthy ecosystem functioning may therefore be as valuable as land-management strategies that aim to enhance the net uptake, and decrease the releases of CO₂ in terrestrial ecosystems, the so-called terrestrial sinks (and sources) of the Kyoto Protocol.

It is beyond the scope of this chapter to attempt a detailed review of the different schemes for ecosystem carbon management that have been proposed, or their economic, ecological, and social impacts. The IPCC has provided in-depth analyses in two major reports released in 2000⁴² and 2001,⁴³ and good practice guidelines for managing terrestrial forest ecosystems in the context of carbon sequestration.⁴⁴ The various forest ecosystem management activities that have been proposed^{43,45} can be grouped into three broad approaches:

1. Strategies to maintain and preserve existing forests
2. Strategies to increase the area of land under forest
3. Strategies to increase the carbon stock density on the forested land (C ha⁻¹)

Much of the focus on carbon sequestration in forests ecosystems has been on enhancement of aboveground biomass as a natural extension of timber production forestry. Recently, a shift to more comprehensive ecosystem management appears to be taking place, together with renewed opportunities and interest in rehabilitating degraded lands, mitigating the effects of deforestation, and managing for natural values (such as wildlife or water quality), not merely for timber. The success of different approaches in any given region depends on prevailing social, economic, and historical conditions. In some regions such as in the central part of Canada, slowing, halting, and mitigating deforestation associated with infrastructure may provide the most efficient strategy, while in other regions, such as central British Columbia, more traditional timber production approaches combined with protection from disturbance may be more attractive.

Protection against disturbance is not, of itself, an efficient or long-term mitigation measure. This is especially true of wildfire where large expenditures simply protect carbon are analogous to paying high rent: the carbon is retained only as long as the

protection continues and is lost when the next fire comes along. However, if the protected area is subsequently harvested, transferring carbon to long-lived forest products, and successfully regenerated, a potentially significant carbon gain can be realized — both within the offsite and within the forest ecosystem pools (Figure 9.3). In the forest ecosystem, the combination of protection and harvesting can be visualized as an increase in the effective rotation length (see Figure 9.4), and as demonstrated by Kurz et al.⁴⁶ the transition from a natural disturbance regime to a managed one (including protection) can have positive carbon benefits.

Increased carbon stocks can also be accomplished through techniques that reduce the time for stand establishment (such as site preparation, planting, and weed control), increasing resources (especially nutrients) required for growth, or through the selection of species that are more productive for a particular area. Decreasing the losses can be accomplished through modification of harvesting practices such as low-impact harvesting (reduce damage to residual trees and soil structure), increased efficiency (reduced logging residue), and managing residues to leave carbon on site.⁴⁵ Despite the interest in all of these techniques, fundamental scientific questions remain about how the ecosystems will respond to a rapidly changing climate, including the allocation of photosynthate between above- and belowground compartments, regeneration success, growth vs. respiration responses — all of which have a direct influence on the carbon benefit a given technique will achieve.

Nutrient fertilization has long been used to enhance stand productivity and can result in increased C stocks in trees and soils,⁴⁷ but its success is dependent on the site conditions, and is therefore potentially susceptible to rapid climate changes. For example, on more fertile sites the effect of fertilization is reduced as other factors begin to limit growth.⁴⁸ For planting, species selection and stocking are important considerations and, depending on the management objective, planting fast-growing species such as hybrid poplar can yield high carbon accumulation rates in early years.⁴⁹ For long-term sequestration, however, planting species adapted to the local climate may be more effective.⁴⁹ But what will be the local climate as the trees approach maturity?

In all such interventions aimed at increasing forest ecosystem, or offsite, carbon stocks, it is necessary to account for fossil fuel consumed in plantation establishment, maintenance, and harvesting (see Figure 9.3). Thus while short rotation plantations can provide an excellent opportunity to displace fossil fuel and, at the same time provide (on average) a significant carbon stock in the plantation, significant direct and indirect (fertilizer production) expenditures of fossil fuel are usually required to realize these gains. An overview of forest-relevant, C sink-source interventions is provided in Table 9.1.

9.6.2 MANAGING PRODUCTS AND SERVICES DERIVED FROM FORESTS FOR C BENEFITS

Products extracted from managed forest ecosystems play multiple roles in the global carbon cycle:

TABLE 9.1
Classes of Management Activities, Cost and Benefits

Intervention	Cost	Maintain and Preserve Existing Forests	Comments	Short Term (<25 yrs)	Longer Term
Preserve primary forests ^a	Future opportunity costs		No new sink added		+
Halt/slow deforestation	Eliminate causes		Sink already accounted for Big avoided emissions	++++	+++ -Va --Va
Halt logging ^a	Forgone economic activity		Loss of forest services	+	
Increase Forest Area					
Afforestation and reforestation ^{ab}	Loss of land for other purposes		One-time C gain	++	-Va,c
Establish and manage reserves	Future opportunity costs?		One-time C gain	+	-Va,c
Multiple use (e.g., agroforestry, shelterbelts)			Cross sectoral benefits	+	+
Restoration of degraded lands	Feasibility?		Reason for degradation ameliorated?	++	-Va
Urban forestry			Energy costs/benefits	+	-Vc
Increase Carbon Density (C ha⁻¹)					
Longer rotation length			Reduced short-term yield of products?	++	-Va,c
Enhance tree productivity	Implementation cost				+Va, -Vc
Control stand density (thinning)	Implementation cost		Timber benefit but total biomass and DOM C?	-?	-Vc
Enhance nutrient availability	Implementation cost Feasibility		Energy costs	++	Va
Control water table	Implementation cost, Increased CO ₂ , reduced CH ₄		Soil respiration, tree growth	+	-Vc

Selected species and genotypes					
Protect from natural disturbance, reduce risk	Implementation cost				
Reduced impact logging	Feasibility				
Reduce regeneration delay	Implementation cost				
Manage onsite logging residues	Implementation cost				
		Response to climate? Cost; diversity impacts			
		Requires ongoing maintenance	+		--Vc
		Cost, extent	?		--Va,c
		Small one-time gain	+		+Va
		Forgone use in products?	+		+Va,c

Note: Number of +'s (-'s) indicates expected magnitude of C benefit (decrement), Vc indicates expected vulnerable to climate change, and Va indicates potentially vulnerable to changes in human activity.

^a Kauppi et al.,⁴³ Fig. 4.8.

^b Includes savannah thickening as a special case.

1. They act as an offsite, manageable carbon reservoir.
2. They can be burned to provide a renewable source of energy (direct substitution).
3. They substitute for competing materials having a larger atmospheric CO₂ footprint (indirect substitution).

Both direct and indirect substitution can add significantly to the mitigation potential of forest products.

9.6.3 FOREST PRODUCTS AS A MANAGEABLE CARBON POOL

From a global perspective, the export of organic carbon from the forest ecosystem where the CO₂ is initially withdrawn from the atmosphere by photosynthesis to a different location where it subsequently decomposes and releases the CO₂ back to the atmosphere, results in a spatial displacement of the source component (at the site of the decomposing product) relative to a comparable sink component (in the forest ecosystem). The net effect on atmospheric concentration is negligible unless the rate of decomposition in the geographically displaced product pools is different from that in the forest ecosystem from which it was removed. This separation of apparent source (forest product) and sink (forest ecosystem) has interesting political implications that have, to date, led to an impasse in attempts to incorporate forest product carbon management in the Kyoto Protocol (who gets the credit — the exporting country in whose forest the uptake of CO₂ took place, or the receiving country where the forest product reservoir management occurs?).

Despite these political difficulties, the carbon contained in forest products makes a small, and manageable, contribution to the global carbon balance. The geographical displacement of forest ecosystem uptake (sink) from the forest product decomposition (source) may also be required for reconciliation of observed geographical distributions of atmospheric CO₂ concentrations with atmospheric transport of CO₂ from known emission sources and sinks.^{50,51}

As a carbon reservoir, the size of exported product pools is the cumulative difference between harvest inputs and depletions through decomposition and combustion that release CO₂ back to the atmosphere. Estimating the size of this pool and its change over time is complicated by at least three factors: the difficulty of tracking the flows of forest products through the multitude of uses society has found for wood products; accounting for the changes over time in the reuse and recycling of woody materials (including pulp and paper); and the wide geographical dispersal of the products through trade (increasingly international). These factors make it difficult to compile inventories of products with widely different half-lives, to estimate the rates of product recycling between different half-lives, and to determine the rates of decomposition and combustion (releasing CO₂ back to the atmosphere) at each stage in the product life cycle, each of which depends on the nature of the product, its use, level of protection, and the local environment in which it is used and discarded.

Despite these inherent uncertainties, estimates of the forest product pools have been made at the global scale, where the pool is thought to be relatively small —

between 5 and 10 Gt C.⁴³ Despite its small size, the IPCC concluded that the potential for an increased contribution to mitigating human perturbations to the global carbon cycle are not insignificant: wood products “already contribute somewhat to climate mitigation, but if infrastructures and incentives can be developed, wood and agricultural products may become vital elements of a sustainable economy: they are among the few renewable resources available on a large scale.”⁴³

An increasing products pool releases proportionally more CO₂. For a steady rate of harvest inputs, the forest products pool in any given region eventually tends to reach a plateau, at which point the accumulated forest products’ releases of CO₂ become equal to the harvest inputs derived from the forest uptake of CO₂. This may be the reason analyses of forest product contributions to the national carbon balance for countries with a long history of forestry, such as in Fennoscandia⁵² and the U.S.,⁵³ tend to be relatively small. Where the forest product pools are young (and not yet saturated), or where the harvest rate is increasing, the increases in the forest product pool may still be significant. In Canada, for example, both of these factors may be responsible for the increases of 23.5 Tg C yr⁻¹ during the late 1980s — of the same magnitude and nearly offsetting the net decreases (due to increased natural disturbances) in the carbon stocks of Canada forests for the same period.⁵⁴

Although the decision has not yet been made on whether, or how, forest product carbon pools will be accounted for under the Kyoto Protocol, there is little doubt that their wise management can offer some degree of mitigation of the increases in atmospheric CO₂. Some general observations may help to guide management decisions.

- Once harvest inputs cease, product pools can only act as a source of atmospheric CO₂ as they decompose or are incinerated as waste. On the other hand, the CO₂ sink generated in the regrowing forest was “created” by the very act of harvesting and over time exactly balances the source term, provided there was no degradation or improvement of site productivity. The source (decomposing or burned product) and the sink (regrowing forest) are inherently linked; they are autocorrelated with a time delay.
- Forest products and the regrowing forest also constitute a spatially displaced source–sink pair with the emission and uptake occurring at different geographical locations. This spatial displacement presents political challenges as the source and sink may therefore be accredited or debited to different parties. It also arises in atmospheric inversion studies, which must deal with the spatially separated CO₂ emissions–receptor pair.^{50,51}
- Retention of carbon in forest products is functionally similar to retention in ecosystem detrital pools: if the half-life of carbon in the products is greater than the natural half-life in the ecosystem, there is a net gain in retained carbon in the forest managed for timber supply relative to the natural ecosystem having the same age distribution.⁵⁵
- The rate of loss from product pools is, in principle, under the control of society through decisions made on the duration of use of the products and their recycling fate. This includes also their final use as a source of energy (see below).

- As a rule of thumb, using long-lived forest carbon stocks to generate short-lived forest products has a disproportionately positive impact on CO₂ emissions, relative to preserving the forest ecosystem stocks,⁵⁶ but this conclusion does not hold if the end use in the product chain is bioenergy that substitutes for fossil fuel.

9.6.4 USE OF FOREST BIOMASS FOR BIOENERGY

In addition to their modest role as a manageable carbon reservoir, forest-derived organic materials can also serve to reduce anthropogenic emissions in two important ways: by supplying essential products and services that otherwise entail greater fossil fuel CO₂ emissions, and by directly supplying energy services (bioenergy). Figure 9.3 shows this emission reduction role as a control on the fossil fuel emissions.

Forest biomass is one of the oldest harnessed sources of energy for human activities, providing both domestic heating and cooking functions, and as an industrial source of energy (see Reference 57 and references therein). Globally, bioenergy at present supplies about 14% of the primary energy needs.⁴² Where sustainably produced bioenergy replaces, or avoids, the combustion of fossil fuel, it has a lasting influence on the global carbon cycle, as explained below. The extent to which sustainably produced forest products supply essential services that otherwise would result in higher emissions from fossil fuel use, in their manufacture, or their operation, or their maintenance, makes a similar contribution. Moreover, the avoidance of emission sources (Figure 9.2) can be additional to the role of forest products as a managed carbon reservoir discussed above. Both the manufacturing residues generated during their production, and the forest products themselves after their serviceable life, can be used to feed bioenergy supply systems.⁵⁷⁻⁵⁹

The trend of increasing replacement of traditional wood-based construction products by cement, metals such as steel and aluminum, and plastics has an adverse impact on the global carbon cycle by increasing the combustion of fossil fuel for their production. For example, the CO₂ emissions associated with electrical transmission line towers is estimated at ~10 t C km⁻¹ when manufactured from tubular steel and ~4.3 t C km⁻¹ from concrete, in contrast to the ~1 t C km⁻¹ estimated for roundwood poles.⁶⁰ Similar ratios are found for other materials such as aluminum and plastic, which require expenditures of energy in their production,⁶⁰ but which are increasingly becoming substitutes for traditional wood products.

Halting the increase in use of metal and plastic products in replacement of wood products or increasing the substitution of these energy-intensive products by wood benefits the carbon budget in multiple ways. The first is the energy expenditure avoided, which is the net difference in CO₂ emissions required to generate the product from the raw materials. The second is the accrual of carbon in the forest products pool. The third, with a longer-lasting impact, is the use of discarded forest products for the production of bioenergy.

The importance of the contributions of forest products to emission reductions lies in the relative permanence of the CO₂ influence on the global carbon cycle. The combustion of fossil fuels and forest biomass for energy both release comparable amounts of CO₂ to the atmosphere for the similar amounts of energy,⁵⁷ and both

fuel sources ultimately derive from the same source: the conversion of solar energy to chemical bonds in organic carbon compounds through the process of photosynthesis. Fossil reserves, however, were accumulated over millennia, with natural inputs to and emissions from these deeply buried reservoirs occurring only slowly on geological timescales. Until recently, the fossil reserves have played a negligible part in the active global carbon cycle. Human withdrawal of fossil fuel from these relatively inert reservoirs has effectively added new carbon to the active global carbon cycle at a rate that has increased dramatically over the last 100 years. In contrast, the burning of (modern) biomass simply returns to the atmosphere the CO_2 that was accumulated from the atmosphere in recent times, adding no new carbon to the active global carbon cycle. Provided the forest ecosystems providing the feedstock are managed sustainably,* there is no direct global change in the atmospheric CO_2 concentration from the combusting modern biomass for energy, although there may be additional emissions associated with the infrastructure for bioenergy systems.

Bioenergy derived from forest ecosystems takes many forms, ranging from dedicated bioenergy plantations to co-generation of heat and electricity as a by-product of product manufacture, and the capture and combustion of methane from landfills. The net impact on the global carbon cycle varies with the efficiency of these production systems and the extent to which the expenditure of fossil fuel is required in their production, distribution, and use.⁵⁷ In addition, the economic feasibility depends strongly on the availability of land for bioenergy purposes, with costs rising steeply if other production uses are displaced.^{57,61}

Including both forest and agricultural systems, global bioenergy production in the year 2050 could be between 95 and 280 EJ (1 EJ is 10^{18} joules = $2.28 \cdot 10^{15}$ KWhrs).⁶² This would supply 5 to 25% of the projected energy needs under some future development scenarios,⁶³ and potentially avoid fossil fuel emissions of 1.4 to 4.2 Gt C yr⁻¹ in 2050.⁶⁴ The maximum potential of bioenergy could be as much as five times greater,⁶² but this would require significant infrastructure development. Similar projections of ~ 4 Gt C yr⁻¹ avoided fossil fuel emissions and carbon sequestration by about 2040 were estimated in computer simulations of an ambitious global program of sustainable development of community-scale short-rotation bioenergy plantations estimated by Read 1999, as reported by Sampson et al.⁶⁵

9.7 CONCLUSIONS: THE GLOBAL FOREST SECTOR AND THE GLOBAL CARBON CYCLE

We asked initially if forests were part of the problem or part of the solution, and have tried to show that they are part of both. Forests and their management are not the largest source of the problem, nor can they be its sole solution. However, our past and present use of the forest land base, especially through deforestation, has had and continues to make a double contribution to the increase in atmospheric CO_2 through the reduction in the planet's photosynthetic capacity, and through the elimination or dramatic reduction of the carbon stocks associated with the former forests.

* "Sustainable" in this context means that the net forest ecosystem uptake of CO_2 (NEP) is at least as great as the net CO_2 emissions from the combustion of the exported biomass.

This is an important part of the problem. Reduction of the rate of deforestation will have an immediate and lasting impact on CO₂ emissions and on atmospheric CO₂ concentrations, in addition to other associated environmental benefits.

Forest responses to changes in the global environment, including Earth's climate, may also contribute to both the problem and its solution.

Although terrestrial ecosystems appear to currently accommodate nearly 60% of the direct anthropogenic perturbation inputs of CO₂ to the atmosphere, the natural physiological mechanisms that are thought to be responsible for this increased uptake are not likely to function as effectively in the future. Thus, in the absence of purposeful mitigation, the land-based CO₂ sink will likely decrease and could even become a source over the coming century,⁶⁶ leading to even greater climate changes.

Sustainable development in forestry has an important role to play in reversing these trends. This role is not restricted to the maintenance or enhancement of carbon stocks in forest ecosystems, but also can help to alleviate the underlying causes of deforestation by providing economic benefits. Although there are many activities that can be undertaken in the management of forest ecosystems to this end, their specific costs will vary. As climate change proceeds, more expensive activities will become necessary for additional mitigation.

The sustainable use of forest products, including the production of energy supplies that displace the use of fossil fuels, may make a significant contribution to mitigate climate change in the longer term because such use avoids the entry of new carbon into the active part of that cycle, while supplying essential goods and services to society. These avoided emissions accrue both from the use of forest biomass to supply energy (either directly or as a last stage in the life cycle of forest products) and from the use of forest-derived products as substitutes for materials that require large expenditure of energy (typically from the combustion of fossil fuels).

Management activities that enhance or protect carbon stocks in forest ecosystems include reducing the regeneration delay through seeding and planting, enhancing forest productivity, changing the harvest rotation length, the judicious use of forest products, and forest protection through control and suppression of disturbance by fire, pests, and disease. At the same time, the flow of material goods and services from a thriving forest products sector not only reduces the dependence on more energy-intensive products, such as cement, but also provides economic benefits that can help pay for such forest-enhancing activities. The sustainable use of forests thereby offers a potential win-win situation: maintenance of carbon stocks in healthy forest ecosystems, the cost of which can be offset by the continuous stream of forest products, which themselves help avoid the direct input of new carbon into the atmosphere. Good forestry can be part of the solution.

Protection of forest carbon stocks from intensifying and recurring disturbance events solely as a mitigation strategy is likely neither efficient nor effective as a long-term measure. This is especially true of wildfires where increasingly large financial expenditures will be needed to protect vulnerable forests. The situation is analogous to paying high rent: C pools are only retained as long as the protection continues, and are lost when the next fire comes along. On the other hand, if protection is coupled with sustainable forest utilization, transferring C to long-lived

forest products, then potentially significant gains in terrestrial C retention can be realized, both on- and offsite.

Although it is straightforward to quantify the direct anthropogenic inputs of CO₂ to the atmosphere, a quantitative understanding of the rates of atmospheric increase remains a challenge, precisely because of the strong feedbacks exerted by terrestrial and ocean ecosystems to the changes. Understanding the biospheric feedback — the response of the world's biota to the perturbations — is needed:

- To gauge the magnitude of future impacts
- To identify realistic mitigation opportunities that can help reduce or avoid further adverse perturbation of the C cycle–climate system
- To design, implement, and monitor appropriate mitigation activities
- To design and implement adaptation strategies that can help society to cope with those changes that are unavoidable

The quantification of C-related costs and benefits from sustainable forest management, and of the impacts of climate change on forest C sinks and sources also remains a challenge, requiring:

- Improved methods and data for assessing vulnerable C pools and the processes affecting them
- New and improved models for predicting the fate of these pools in a changing environment
- New tools and data to monitor and verify the predictions over large scales

Over the past decade, there has been a dramatic improvement in the science of interactions between climate and forests. Particular advances have been made in understanding landscape-level carbon dynamics through the implementation of large-scale manipulative experiments and advanced monitoring programs, and in the development of practical forest-oriented remote-sensing technologies. Further advances are critically important to understand the dynamics and impacts of human activities on changing carbon uptake by terrestrial ecosystems. Part of this challenge is the identification of mitigation opportunities that can help reduce or avoid further adverse perturbation of the carbon cycle–climate system. A significant component of this is the development of predictive tools that incorporate human decision making and social behavior as an integral part of the analytical process. This task has recently been initiated by the Global Carbon Project of the Earth Systems Partnership.⁶⁷

ACKNOWLEDGMENTS

This chapter is based in part on an earlier presentation by M.J.A. at the XII World Forestry Congress. The authors thankfully acknowledge the thoughtful comments by two anonymous reviewers.

REFERENCES

1. Zwiers, F.W. 2002. The 20-year forecast. *Nature* 416:690–691.
2. IPCC. 1990. *Climate Change 1990: IPCC Scientific Assessment*. Cambridge University Press, New York.
3. IPCC. 2001. *Climate Change 2001: The Scientific Basis. Contribution of Working Group I to the Third Assessment Report of the Intergovernmental Panel on Climate Change*. Cambridge University Press, Cambridge.
4. Reilly, J., P.H. Stone, C.E. Forest, M.D. Webster, G.C. Jacoby, and R.G. Prinn. 2001. Uncertainty and climate change assessments. *Science* 293:430–433.
5. WMO. 2002. WMO Statement on the status of the global climate in 2001. WMO-No. 940, World Meteorological Organisation, Geneva.
6. Apps, M.J. and W.A. Kurz. 1991. The carbon budget of Canadian forests in a changing climate: can forestry be part of the solution? In *Proceedings 3rd International Symposium on Cold Region Development*, “ISCORD ’91,” Edmonton, June 16–20, 1991. Alberta Research Council, 48 pp.
7. Falkowski, P., R.J. Scholes, E. Boyle, J. Canadell, D. Canfield, J. Elser, N. Gruber, K. Hibbard, P. Hogbeg, S. Linder, A.F. MacKenzie, B. Moore III, T.F. Pedersen, Y. Rosenthal, S. Seitzinger, V. Smetacek, and W. Steffen. 2000. The global carbon cycle: a test of our knowledge of Earth as a system. *Science* 290:291–296.
8. Marland, G., R. Pielke, Sr., M. Apps, R. Avissar, R.A. Betts, K.J. Davis, P.C. Frumhoff, S.T. Jackson, L.A. Joyce, P. Kauppi, J. Katzenberger, K.G. MacDicken, R.P. Neilson, J.O. Niles, D.S. Niyogi, R.J. Norby, N. Pena, N. Sampson, and Y. Xue. 2003. The climatic impacts of land surface change and carbon management, and the implications for climate-change mitigation policy. *Climate Policy* 3:149–157.
9. Melillo, J.R., C.B. Field, and B. Moldan. 2003. Element interactions and the cycles of life: An overview. In *Interactions of the Major Biogeochemical Cycles: Global Change and Human Impacts*, J.M. Metillo, C.B. Field, and B. Moldan, Eds. Island Press, Washington, D.C., 1–14.
10. Houghton, R.A. 2003. Revised estimates of the annual net flux of carbon to the atmosphere from changes in land use and land management 1850–2000. *Tellus* 55B(2):378–390.
11. Schulze, E., D.C. Wirth, and M. Heimann. 2000. Managing forests after Kyoto. *Science* 289:2058–2059.
12. Barford, C.C., S.C. Wofsy, et al. 2001. Factors controlling long- and short-term sequestration of atmospheric CO₂ in a mid-latitude forest. *Science* 294:1688–1691.
13. Gholz, H.L. and R.F. Fisher. 1982. Organic matter production and distribution in slash pine (*Pinus elliottii*) plantations. *Ecology* 63:1827–1839.
14. Gower, S.T., O.N. Krankina, R.J. Olson, M.J. Apps, S. Linder, and C. Wang. 2000. Net primary production and carbon allocation patterns of boreal forest ecosystems. *Ecol. Appl.* 11:1395–1411.
15. Kurz, W.A. and M.J. Apps. 1999. A 70-year retrospective analysis of carbon fluxes in the Canadian forest sector. *Ecol. Appl.* 9:526–547.
16. MacLaren, J.P. 1996. Plantation forestry — its role as a carbon sink: conclusions from calculations based on New Zealand’s planted forest estate. Pages 257–270 In *Forest Ecosystems, Forest Management and the Global Carbon Cycle*, M.J. Apps and D.T. Price, Eds. Springer-Verlag, Berlin, 257–270.
17. Van Wagner, C.E. 1978. Age-class distribution and the forest fire cycle. *Can. J. For. Res.* 8:220–227.

18. Harrington, J. 1982. A Statistical Study of Area Burned by Wildfire in Canada 1953–1980. Information Report PI-X-16, Petawawa National Forestry Institute, Canadian Forestry Service, Department of Environment.
19. Canadell, J.G., H.A. Mooney, D.D. Baldocchi, J.A. Berry, J.R. Ehleringer, C.B. Field, S.T. Gower, D.Y. Hollinger, J.E. Hunt, R.B. Jackson, S.W. Running, G.R. Shaver, W. Steffen, S.E. Trumbore, R. Valentini, and B.Y. Bond. 2000. Carbon metabolism of the terrestrial biosphere: a multi-technique approach for improved understanding. *Ecosystems* 3:115–130.
20. Steffen, W. and P. Tyson. 2001. Global Change and the Earth System: A Planet under Pressure. The Global Environmental Programmes. IGBP Science No. 4, IGBP (International Geosphere-Biosphere Programme), Stockholm.
21. Pacala, S.W., G.C. Hurtt, D. Baker, P. Peylin, R.A. Houghton, R.A. Birdsey, L. Heath, E.T. Sundquist, R.F. Stallard, P. Ciais, P. Moorcroft, J.P. Caspersen, E. Shevliakova, B. Moore, G. Kohlmaier, E. Holland, M. Gloor, M.E. Harmon, S.-M. Fan, J.L. Sarmiento, C.L. Goodale, D. Schimel, and C.B. Field. 2001. Consistent land- and atmosphere-based U.S. carbon sink estimates. *Science* 292:2316–2320.
22. Caspersen, J.P., S.W. Pacala, J.C. Jenkins, G.C. Hurtt, P.C. Moorcroft, and R.A. Birdsey. 2000. Contributions of land-use history to carbon accumulation in U.S. forests. *Science* 290:1148–1151.
23. Keeling, C.D., J.F.S. Chin, and T.P. Whorf. Increased activity on northern vegetation inferred from atmospheric CO₂ measurements. *Nature* 382:146–149.
24. Lavigne, M.B., R. Boutin, R.J. Foster, G. Goodine, P.Y. Bernier, and G. Robitaille. 2003. Soil respiration responses to temperature are controlled more by roots than by decomposition in balsam fir ecosystems. *Can. J. For. Res.* 33:1744–1753.
25. Lavoie, C. and S. Payette. 1996. The long-term stability of the boreal forest limit in subarctic Quebec. *Ecology* 77:1226–1233.
26. Zoltai, S.C., T. Singh, and M.J. Apps. 1991. Aspen in a changing climate. In *Aspen Management for the 21st Century*, S. Navratil and P.B. Chapman, Eds. Forestry Canada, Northwest Region, Northern Forestry Centre and Poplar Council of Canada, Edmonton, Alberta, 143–152.
27. Hogg, E.H. and P.A. Hurdle. 1995. The aspen parkland in western Canada: A dry-climate analogue for the future boreal forest? *Water Air Soil Pollut.* 82:391–400.
28. Hogg, E.H. 2001. Modelling aspen responses to climatic warming and insect defoliation in western Canada. In *Sustaining Aspen in Western Landscapes: Symposium Proceedings*, Shepperd, W.D., Binkley, D., Bartos, D.L., Stohlgren, T.J., and Eskew, L.G., Comps. 13–15 June 2000, Grand Junction, Colorado. U.S. Department of Agriculture, Forest Service, Rocky Mountain Research Station, Fort Collins, Colorado, Proceedings RMRS-P-18, 325–338.
29. Kurz, W.A., M.J. Apps, B.J. Stocks, and W.J.A. Volney. 1995. Global climatic change: disturbance regimes and biospheric feedbacks of temperate and boreal forests. In *Biotic Feedbacks in the Global Climatic System: Will the Warming Feed the Warming?* G.M. Woodwell and F.T. Mackenzie, Eds. Oxford University Press, 119–133.
30. Holling, C. S. 2001. Understanding the complexity of economic, ecological, and social systems. *Ecosystems* 4:390–405.
31. Luo, Y., L.W. White, J.G. Canadell, E.H. DeLucia, D.S. Ellsworth, A. Finzi, J. Lichten, and W.E. Schlesinger. 2003. Sustainability of terrestrial carbon sequestration: a case study in Duke Forest with inversion approach. *Global Biogeochem. Cycles* 17:1021–1034.

32. DeLucia, E.H., K. George, and J.G. Hamilton. 2002. Radiation-use efficiency of a forest exposed to elevated concentrations of atmospheric carbon dioxide. *Tree Physiol.* 22:1003–1010.
33. Oren, R., D.S. Ellsworth, K.H. Johnsen, N. Phillips, B.E. Ewers, C. Maier, K.V.R. Schafer, H. McCarthy, G. Hendrey, S.G. McNulty, and G.G. Katul. 2001. Soil fertility limits carbon sequestration by forest ecosystem in a CO₂-enriched atmosphere. *Nature* 411:469–472.
34. Schindler, D.W. 1998. A dim future for boreal waters and landscapes. *BioScience* 48:157–164.
35. Isebrands, J.G., Dickson, R.E., Rebbeck, J., and Karnosky, D.F. 2000. Interacting effects of multiple stresses on growth and physiological processes in northern forests. In *Responses of Northern U.S. Forests to Environmental Change*, R.E. Mickler, R.A. Birdsey, and J. Hom, Eds. Ecological Studies 139, Springer-Verlag, Berlin, 149–180.
36. Flannigan, M.D., I. Campbell, M. Wotton, C. Carcaillet, P. Richard, and Y. Bergeron. 2001. Future fire in Canada's boreal forest: paleoecology results and general circulation model — regional climate model simulations. *Can. J. For. Res.* 31:854–864.
37. Fleming, R.A. and W.J.A. Volney. 1995. Effects of climate change on insect defoliator population processes in Canada's boreal forest. *Water Air Soil Pollut.* 82:445–454.
38. Dale, V.H., L.A. Joyce, S. McNulty, R.P. Neilson, M. Ayres, M.D. Flannigan, P.J. Hanson, L. Irland, A.E. Lugo, C. Peterson, D. Simberloff, F. Swanson, B.J. Stocks, and B.M. Wotton. 2001. Climate Change and forest disturbances. *BioScience* 51:723–734.
39. McNulty, S. 2002. Hurricane impacts on US forest carbon sequestration. *Environ. Pollut.* 116:S17–S24.
40. Percy, K.E., C.S. Awmack, R.L. Lindroth, M.E. Kubiske, B.J. Kopper, J.G. Isebrands, K.S. Pregitzer, G.R. Hendry, R.E. Dickson, D.R. Zak, E. Okansen, J. Sober, R. Harrington, and D.F. Karnosky. 2002. Altered performance of forest pests under atmospheres enriched by CO₂ and O₃. *Nature* 420:403–407.
41. UNFCCC. 1997. Kyoto Protocol to the United Nations Framework Convention on Climate Change. In *FCCC/CP/1997/7/Add.1*. <http://WWW.UNFCCC.DE>.
42. Watson, R., I. Noble, B. Bolin, M.J. Apps et al. 2000. Summary for Policy Makers, *IPCC Special Report on Land Use, Land-Use Change and Forestry*. Cambridge University Press, New York.
43. Kauppi, P.E., R.A. Sedjo, M.J. Apps, C.C. Cerri, T. Fujimori, H. Janzen, O.N. Krankina, W. Makundi, G. Marland, O. Maser, G.J. Nabuurs, W. Razali, and N.H. Ravindranath. 2001. Technical and economic potential of options to enhance, maintain and manage biological carbon reservoirs and geo-engineering. In *Climate Change 2001: Mitigation. Contribution of Working Group III to the Third Assessment Report of the Intergovernmental Panel on Climate Change*, B. Metz, O. Davidson, R. Swart, and J. Pan, Eds. Cambridge University Press, Cambridge, 310–343.
44. Penman, J., M. Gytarsky, T. Hiraishi, T. Krug, D. Kruger, R. Pipatti, L. Buendia, K. Miwa, T. Ngara, K. Tanabe, and F. Wagner, Eds. 2003. *Good Practice Guidance for Land Use, Land-Use Change and Forestry*. IPCC National Greenhouse Gas Inventories Program, Institute for Global Environmental Strategies, Kanagawa, Japan.
45. Binkley, C.S., M.J. Apps, R.K. Dixon, P. Kauppi, and L.-O. Nilsson. 1998. Sequestering carbon in natural forests. *Crit. Rev. Environ. Sci. Technol.* 27:S23–45.
46. Kurz, W.A., S.J. Beukema, and M.J. Apps. 1998. Carbon budget implications of the transition from natural to managed disturbance regimes in forest landscapes. *Mitigation Adaptation Strat. Global Change* 2:405–421.

47. Nohrstedt, H.O. 2001. Response of coniferous forest ecosystems on mineral soils to nutrient additions: a review of Swedish experiences. *Scand. J. For. Res.* 16:555–573.
48. Saarsalmi, A. and E. Malkonen. E.2001. Forest fertilization research in Finland: a literature review. *Scand. J. For. Res.* 16:514–535.
49. Schroeder, W. and J. Kort. 2001. Temperate agroforestry: adaptive and mitigative roles in a changing physical and socio-economic climate. In *Proceedings of the Seventh Biennial Conference on Agroforestry in North America*, Saskatchewan, Canada, August 12–15, 2001, 350 pp.
50. Fan, S., M. Gloor, J. Mahlman, S. Pacala, J.L. Sarmiento, T. Takahashi, and P. Tans. 1999. The North American Sink. *Science* 483:1815a.
51. Bousquet, P., P. Peylin, P. Ciais, C.L. Querre, P. Friedlingstein, and P. Tans. 2000. Regional changes in carbon dioxide fluxes of land and oceans since 1980. *Science* 290:1342–1346.
52. Karjalainen, T., S. Kellomaki, and A. Pussinen. 1994. Role of wood-based products in absorbing atmospheric carbon. *Silva Fenn.* 28:67–80.
53. Harmon, M.E., J.M. Harmon, W.K. Ferrell, and D. Brooks. 1996. Modeling carbon stores in Oregon and Washington forest products: 1900–1992. *Climatic Change* 33:521–550.
54. Apps, M.J., W.A. Kurz, S.J. Beukema, and J.S. Bhatti. 1999. Carbon budget of the Canadian forest product sector. *Environ. Sci. Policy* 2:25–41.
55. Hendrickson, O.Q. 1990. How does forestry influence atmospheric carbon? *For. Chron.* 66:469–472.
56. Dewar, R.C. 1990. Analytical model of carbon storage in the trees, soils and wood products of managed forests. *Tree Physiology* 6:417–428.
57. Schlamadinger, B., M. Apps, F. Bohlin, L. Gustavsson, G. Jungmeier, G. Marland, K. Pingoud, and I. Savolainen. 1997. Towards a standard methodology for greenhouse gas balances of bioenergy systems in comparison with fossil energy systems. *Biomass Bioenerg.* 13:359–375.
58. Pingoud, K., A. Lehitila, and I. Savolainen. 1999. Bioenergy and the forest industry in Finland after the adoption of the Kyoto Protocol. *Environ. Sci. Policy* 2:153–163.
59. Gustavsson, L., T. Karjalainen, G. Marland, I. Savolainen, B. Schlamadinger, and M.J. Apps. 2000. Project-based greenhouse gas accounting: Guiding principles with focus on baselines. *Energ. Policy* 28:935–946.
60. Richter, K. 1998. Life cycle assessment of wood products. In *Carbon Dioxide Mitigation in Forestry and Wood Industry*, G. Kohlmaier, K. Weber, and R. Houghton, Eds. Springer Verlag, Berlin, 219–248.
61. Schlamadinger, B. and G. Marland. 1996. Full fuel cycle carbon balances of bioenergy and forestry options. *Energ. Conserv. Manage.* 37(6–8):813–818.
62. Hall, D.O. and J.I. Scrase. 1998. “Will biomass be the environmentally friendly fuel of the future?” *Biomass Bioenerg.* 15(4/5):357–367.
63. Nakicenovic, N., J. Alcamo, G. Davis, B. de Vries, J. Fenhann, S. Gaffin, K. Gregory, A. Grübler, T.Y. Jung, T. Kram, E.L. La Rovere, L. Michaelis, S. Mori, T. Morita, W. Pepper, H. Pitcher, L. Price, K. Riahi, A. Roehrl, H.-H. Rogner, A. Sankovski, M. Schlesinger, P. Shukla, S. Smith, R. Swart, S. van Rooijen, N. Victor, and Z. Dadi. 2000. Special Report on Emissions Scenarios. Intergovernmental Panel on Climate Change, Cambridge.
64. Matthews, R. and K. Robertson. 2001. Answers to ten frequently asked questions about bioenergy, carbon sinks and their role in global climate change. Graz, Austria, IEA Bioenergy Task 38, 8 pp.

65. Sampson, R.N., R.J. Scholes, C.C. Cerri, L. Erda, D.O. Hall, M. Handa, P. Hill, M. Howden, H. Janzen, J.M. Kimble, R. Lal, G. Marland, K. Minami, K. Paustian, P. Read, P.A. Sanchez, C. Scoppa, B. Solberg, M.A. Trossero, S.E. Trumbore, O. van Cleemput, A.P. Whitmore, and D. Xu. 2000. Additional human-induced activities, Article 3.4. In *Special Report on Land Use, Land-Use Change and Forestry*, R.T. Watson, I.R. Noble, B. Bolin, N.H. Ravindranath, D.J. Verardo, and D.J. Dokken, Eds. Cambridge University Press, Cambridge, 183–281.
66. Cox, P.M., R.A. Betts, C.D. Jones, S.A. Spall, and I.J. Totterdell. 2000. Acceleration of global warming due to carbon-cycle feedbacks in a coupled climate model. *Nature* 409:184–187.
67. GCP Steering Committee, 2003. Global Carbon Project: The Science Framework and Implementation. Canberra, Earth Systems Partnership (IGBP, IHDP, WCRP, Diversitas): Report 1, Canberra, 69 pp.

Climate Change and Managed Ecosystems

Edited by

J.S. Bhatti

R. Lal

M.J. Apps

M.A. Price



Taylor & Francis

Taylor & Francis Group

Boca Raton London New York

A CRC title, part of the Taylor & Francis imprint, a member of the Taylor & Francis Group, the academic division of T&F Informa plc.

Published in 2006 by
CRC Press
Taylor & Francis Group
6000 Broken Sound Parkway NW, Suite 300
Boca Raton, FL 33487-2742

© 2006 by Taylor & Francis Group, LLC
CRC Press is an imprint of Taylor & Francis Group

No claim to original U.S. Government works
Printed in the United States of America on acid-free paper
10 9 8 7 6 5 4 3 2 1

International Standard Book Number-10: 0-8493-3097-1 (Hardcover)
International Standard Book Number-13: 978-0-8493-3097-1 (Hardcover)
Library of Congress Card Number 2005028910

This book contains information obtained from authentic and highly regarded sources. Reprinted material is quoted with permission, and sources are indicated. A wide variety of references are listed. Reasonable efforts have been made to publish reliable data and information, but the author and the publisher cannot assume responsibility for the validity of all materials or for the consequences of their use.

No part of this book may be reprinted, reproduced, transmitted, or utilized in any form by any electronic, mechanical, or other means, now known or hereafter invented, including photocopying, microfilming, and recording, or in any information storage or retrieval system, without written permission from the publishers.

For permission to photocopy or use material electronically from this work, please access www.copyright.com (<http://www.copyright.com/>) or contact the Copyright Clearance Center, Inc. (CCC) 222 Rosewood Drive, Danvers, MA 01923, 978-750-8400. CCC is a not-for-profit organization that provides licenses and registration for a variety of users. For organizations that have been granted a photocopy license by the CCC, a separate system of payment has been arranged.

Trademark Notice: Product or corporate names may be trademarks or registered trademarks, and are used only for identification and explanation without intent to infringe.

Library of Congress Cataloging-in-Publication Data

Climate change and managed ecosystems / edited by J.S. Bhatti ... [et al].
p. cm.

Includes bibliographical references and index.

ISBN-10: 0-8493-3097-1 (hardcover)

1. Climatic changes. 2. Ecosystem management. I. Bhatti, J. S. (Jagtar S.)

QC981.8.C5C5113823 2006
333.95--dc22

2005028910

informa

Taylor & Francis Group
is the Academic Division of Informa plc.

Visit the Taylor & Francis Web site at
<http://www.taylorandfrancis.com>

and the CRC Press Web site at
<http://www.crcpress.com>